

Split Furnaces - SF2297 Series

For Materials Testing

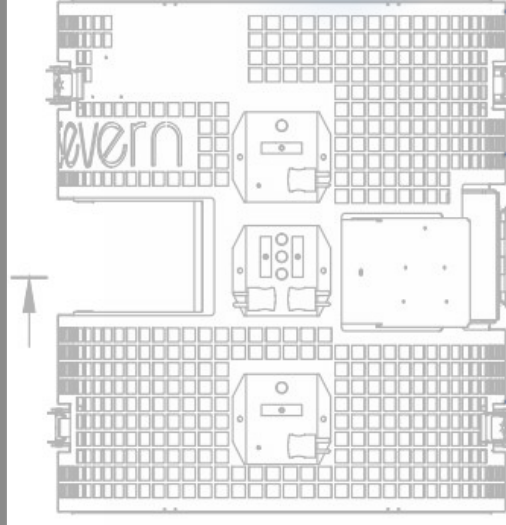
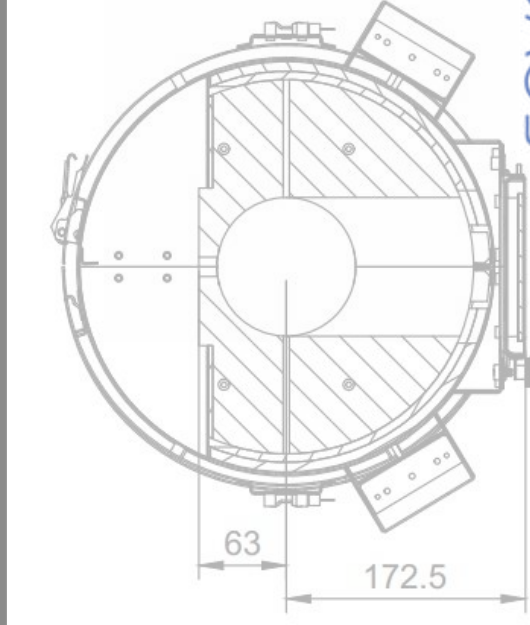
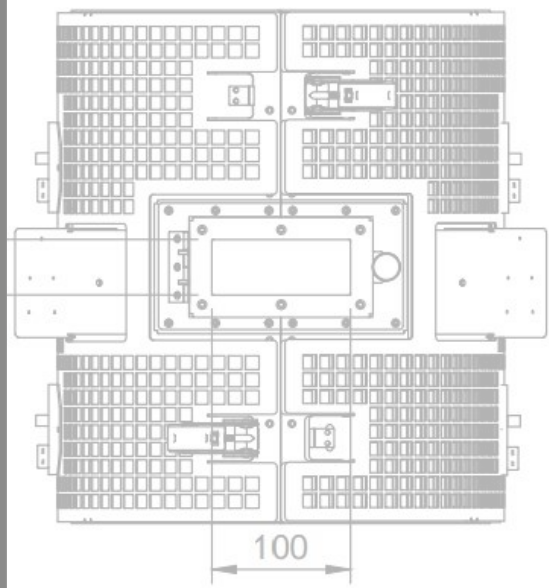
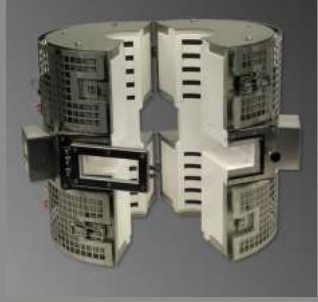
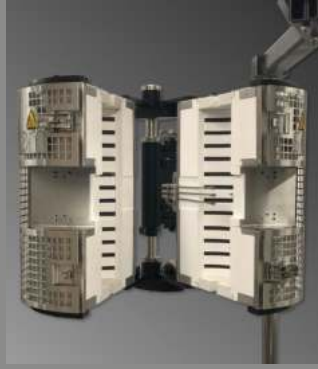

severn thermal solutions

Range & Compatibility

Severn Thermal Solutions has developed the SF2297 range of three zone split furnaces for tensile and fatigue testing at elevated temperatures.

They are available in a number of configurations to suit various contacting extensometry types or may alternatively be fitted with quartz glazed ports for use with optical strain measurement systems and/or thermography equipment.

Typically, they are fitted with sprung loaded specimen contacting thermocouples which may be used for specimen temperature monitoring, via external hardware, or for cascade control when used with the CU2297C Advanced Cascade control system.

Mounting bracketry is available in a wide range of configurations to suit table/floor model electromechanical test systems or two/four column servohydraulic/electrodynamic test systems.

The furnaces referenced in this brochure are typical examples of systems manufactured to suit specific application requirements, should your needs differ please talk to us about customisation.

Design Principles & Advantages

The SF2297 series of split furnaces feature thick gauge resistance wire coils fitted within a split insulation shell formed from body soluble non-RCF fibre insulation. This is backed by a split cylindrical brushed stainless steel case with a brushed stainless steel outer guard. The resultant low thermal mass design offers a number of advantages over 'traditional' split furnace systems fitted with a higher mass refractory tile, including:

- Increased operating temperature capabilities.
- The achievement of faster heating and cooling rates.
- Improved thermal shock resistance (important if opening hot for specimen change/rapid cooling).
- Improved control performance at lower temperatures.

System performance may be further enhanced through the use of our Advanced Cascade control system, developed for high throughput testing in commercial environments.

Temperature control is typically via type N thermocouples inserted into the hot zone through radial thermowells. When used in conjunction with the Advanced Cascade control system specimen mounted sprung loaded thermocouples are used in addition (alternative thermocouple types are available).

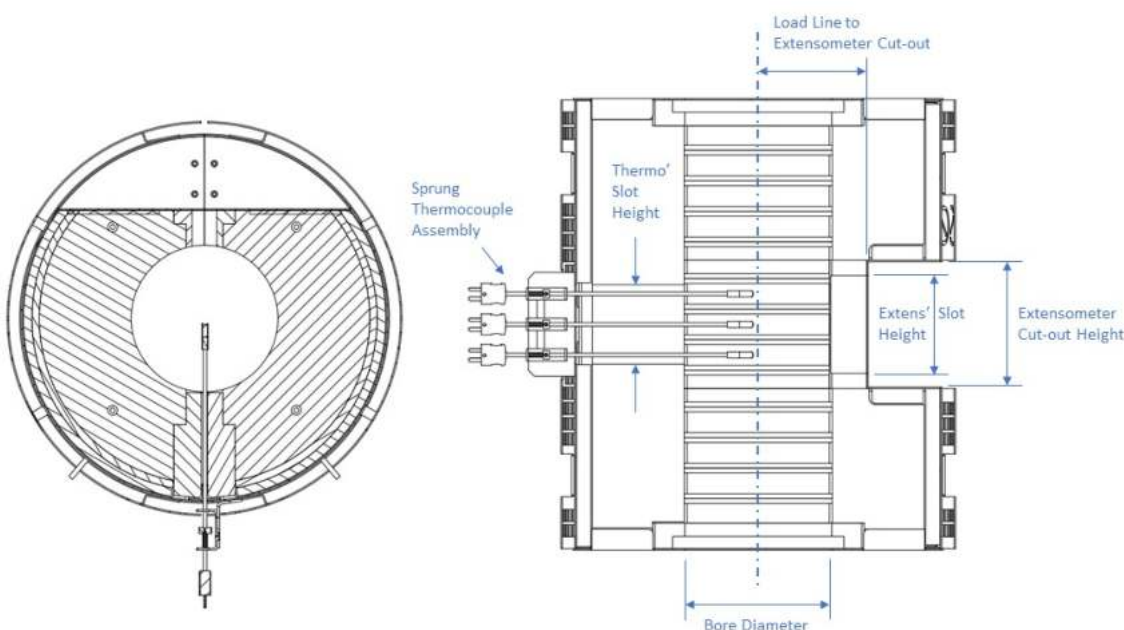

Furnace Variants

SF2297C

This SF2297 variant features a vertical slot on the front split line compatible with high temperature contacting extensometers with relatively long rod lengths.

A rear vertical slot is provided for use with a sprung loaded specimen thermocouple assembly.



SF2297D

This SF2297 variant features a vertical slot on the front split line together with a cut-out compatible with high temperature contacting extensometers with shorter rod lengths.

A rear vertical slot is provided for use with a sprung loaded specimen thermocouple assembly.

SF2297F

This SF2297 variant features a vertical slot on the front split line together with a tall offset cut-out compatible with MFHT5 high temperature variable gauge length contacting extensometers.

A rear vertical slot is provided for use with a sprung loaded specimen thermocouple assembly.



SF2297E

This SF2297 variant features a vertical slot on the front split line together with a cut-out compatible with high temperature contacting extensometers with shorter rod lengths.

A rear quartz glazed window of 100mm x 40mm is provided for use with optical strain measurement/thermography equipment.

Control Systems

A wide range of options are available, from simple independent closed-loop control systems through to more advanced/automated cascade control systems developed for high throughput commercial testing applications.

Eurotherm instrumentation is commonly used, and this may be equipped with a range of communications protocols enabling the furnace/specimen temperature to be remotely monitored/controlled (subject to options selected).

Control systems may easily be configured to meet individual requirements, several of the more commonly supplied variants being described below.

CU2151F

Three independent Eurotherm EPC 3016 programmer controllers together with a 3216i over-temperature alarm. An integrated microswitch circuit isolates power from the heating elements when the furnace is opened. Uses furnace thermowell mounted OR specimen mounted control thermocouples.



CU2151B

Slave/Master configuration using centre zone Eurotherm 3508 Master connected to two end zone 3216 Slaves, together with a 3216i over-temperature alarm. An integrated microswitch circuit isolates power from the heating elements when the furnace is opened. Uses furnace thermowell mounted OR specimen mounted control thermocouples.

CU2297C

Eurotherm 2704 multi-loop controller featuring an internal algorithm developed to maximise heating rates without overshoot. Features a 3216i over-temperature alarm and integrated microswitch circuit which isolates power from the heating elements when the furnace is opened.

Uses furnace thermowell mounted AND specimen mounted control thermocouples.

The optimal solution for commercial testing and/or when tests at low temperatures are required.

The graph (right) shows typical heating and stabilisation times for a range of specimen temperatures when used with 25mm dia pull rods.

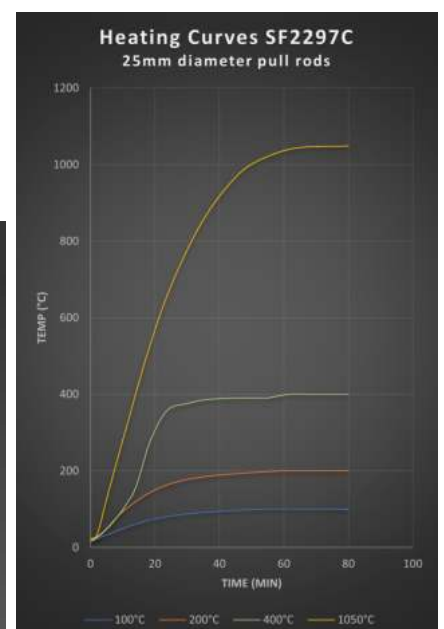

Furnace Support Bracketry

Based on a number of standardised configurations furnace support bracketry is typically engineered to suit the machine on which the furnace is to be mounted, taking into account machine type, column size/separation, amount of clearance required for specimen replacement, etc.

The majority of such brackets feature tilt adjustment to ensure that the furnace is accurately aligned with the loadstring, which is particularly important when equipping with furnace mounting extensometry. Components are typically chrome plated mild steel in combination with either powder coated mild steel or hard anodised aluminium.

The examples shown below are illustrative, please contact us to discuss your specific requirements.



Multiple furnaces, screw cover mounted (subject to screw cover stiffness)



Twin furnaces attached to rear mounted pillars (servohydraulic/servolectric)



Single furnace column mounted (servohydraulic/servolectric)



Single furnace twin column mounted (servoelectric/creep)



Twin furnaces column mounted (servohydraulic/servolectric)



Twin furnaces attached to rear mounted pillars (electromechanical)

Please refer to our '**Furnace Carousel Systems**' brochure for related solutions for high throughput commercial tensile testing.

Specifications

SF2297 Series Split Furnaces

Furnace Model	Bore Dia (mm)	Overall Dia (mm)	No of Zones	Hotzone Height (mm)	Overall Height (mm)	Max Temp (°C)	Rear Thermocouple Slot (mm)	Front Extensometer Slot/cut-out	Power (kW)
SF2297C	120	322	3	325	370	1200	5 x 60	Slot 60mm x 10mm centrally positioned (no cut-out)	3.3
SF2297D	120	322	3	325	370	1200	5 x 60	105mm high cut-out centrally positioned, 89.7mm from load line, slot 76mm x 12mm (Max)	3.3
SF2297E	100	322	2	325	370	900	n/a	80mm high cut-out centrally positioned, 63mm from load line, slot 60mm x 12 (max). Rear Quartz glazed window W100mm x H40mm, 173mm from load line	2.2
SF2297F	120	322	3	325	370	1200	5 x 60	165mm high cut-out offset towards bottom, 137mm from load line, slot centrally positioned 70mm x 10mm	3.3

Notes

- Top/bottom insulation pieces are removable, with port diameters typically being sized to suit the pull rod dimensions.
- Alternative slot/cut-out/window configurations available on request.
- Control systems are typically configured for type N thermocouples, alternative types, K, R, S available on request.

Temperature Control Systems

Controller Model	Type	Primary Instrument	Secondary Instruments	Over Temperature Alarm	Microswitch Circuit	Digital Communications	Supply
CU2151F	Three independent zones	Eurotherm EPC3016 8 segment	Eurotherm EPC3016 8 segment	Eurotherm 3216i	Included	RS485	230V 16A single phase
CU2151B	Slave/Master	Eurotherm 3508 20 segment	Eurotherm 3216	Eurotherm 3216i	Included	RS232 to Master	230V 16A single phase
CU2297C	Advanced Cascade	Eurotherm 2704 multi-loop	n/a	Eurotherm 3216i	Included	RS232	230V 16A single phase

Notes

- CU2297C has been optimised for high throughput standardised testing. The controller uses pre-set internal algorithms to ramp from current temperature to set-point without overshoot and without any requirement for operator tuning/adjustment. It is not suited to experimental applications where user defined programmed ramps/holds are desired. Specimen uniformity information can be derived from instrument readouts.
- Alternative communication protocols available on request.
- Current variants all feature screen printed front panels (in place of adhesive labels shown in some images).

Alternative Split Furnace Designs

Severn Thermal Solutions have a wealth of experience in the design and manufacture of customised split furnaces, engineered to suit specific application requirements, both materials testing and process related.

Encompassed heater technologies include resistance wire, Silicon Carbide, Molybdenum Disilicide and Quartz infra red lamps.

Representative examples can be seen below:



Three zone Silicon Carbide heated 'short furnace' SF2151A with rear mounted specimen thermocouple assembly. Designed for a maximum element temperature of 1400°C



Three zone Molybdenum Disilicide heated split furnace MDS2296A. Designed for a maximum furnace temperature of 1550°C



Three zone Silicon Carbide heated furnace SC2315. Designed for furnace temperatures of 1500°C in air, 1250°C under dry Nitrogen



Two zone Molybdenum Disilicide heated 'short furnace' MDS2310. Designed for a maximum furnace temperature of 1500°C

The furnaces depicted above represent a small selection of the vast array of designs developed by Severn Thermal Solutions, please contact us to discuss any non-standard requirements.



Severn Thermal Solutions designs and manufactures High Temperature Furnaces and Environmental Chambers for a wide variety of Materials Testing and Laboratory applications. We also undertake the repair/refurbishment of existing furnace systems.



severn thermal solutions

Unit C1 & C2
Draycott Business Park
Dursley
GL11 5DQ
United Kingdom

Tel: +44 (0) 1453 891880
Email: sales@severnnts.co.uk
Web: www.severnnts.co.uk

Specifications may be subject to change without notice.

SF2297-SER-01-06.21